

Description

The HPR10 power relay belongs to E-T-A's product group of high-current relays. The hybrid version also features the electro-mechanical relay system plus an active electronic control unit for signal conditioning. This creates a wide range of options regarding activation and functionality of the power relay. These relays are designed for the use in utility vehicles and can switch up to 300 A continuous load and carry DC 12 V, 24 V or 48 V. Due to the high number of switching cycles at rated load, including capacitive and inductive loads, these power relays are particularly suitable for demanding applications in the utility vehicle sector. The main terminals are stud terminals. Various mounting options for horizontal or vertical mounting of the module are available, such as side flange, foot flange and M4 sockets. This allows the direct replacement of the previous conventional cylindrical relays, but also other flexible fittings. This means that E-T-A power relays can replace all conventional power relays on the market.

US patent number: US 10,249,462 B2

US patent number: US 9,728,360, B2

Versions

- single-pole make contact
- side mount flanges as standard version
- extendable mounting with foot flange or side flange with standard hole sizes and also customised mounting methods
- standard: screw terminals for the activation
- 3-pole automotive plug-in connector, compatible with Tyco HDSCS series (group A, black coding)
- Extension to 48 V in the load circuit

Target industries

- Utility vehicles
- Buses
- Trucks
- Construction machinery (cranes, excavators, dump trucks etc.)
- Specially vehicles (emergency, service, municipal)
- Agricultural vehicles (tractors, harvesters etc.)
- Automated guided vehicles

Approvals

Approval authority	Logo	Directive
KBA	E1	ECE-R10

Compliance



Features

- water-proof and dust-proof
- side mount and foot mount
- low weight
- long typical life
- high continuous current
- low current consumption and power loss
- wide temperature range
- integral free-wheeling diodes
- barrier between main terminals

Options

Optional functions are available, e.g.

- ON or OFF delay
- under-/overvoltage detection and corresponding automatic disconnection (load shedding) or automatic reset

Applications

- battery isolation switch or battery switch-over relay
- switching of high-capacity loads (examples: air-conditioning, compressor units)
- Replacing massive cylindrical standard power relays in utility vehicles and relays for applications with extreme requirements, e.g. in construction machinery
- Contactors in industrial trucks and automated guided vehicles

Technical data		
Load circuit		
Voltage rating	U_N	12 V DC, 24 V DC, 48 V DC
Continuous current	I_N	100 A, 200 A, 300 A
Overload	20 s	$2 \times I_N$
	1 s	$8 \times I_N$
Contact voltage drop	max. 150 mV	(initially)
	max. 175 mV	(after typical life)
Control circuit		
Operating voltage	12 V DC:	24 V DC:
	9 ... 16 V DC	16 ... 32 V DC
Quiescent current	< 0.4 mA	
Control current at U_N	< 1.5 mA	< 3.0 mA
General		
Typical life	> 500,000 cycles	
mechanical ohmic	12 V	> 400,000 cycles at I_N
	24 V	> 200,000 cycles at I_N
	48 V	> 20,000 cycles at 300 A
	48 V	> 40,000 cycles at 100 A
Dielectric strength	1050 V / 1 min	to ISO 16750-2, Code F
Insulation resistance	> 100 M Ω (initially)	to ISO 16750-2, chap. 4.12
Temperature range	-40 ... +85 °C	
Degree of Protection	enclosure	IP 6K9K, IP X6k, IP X7
	terminal area	IP00 to ISO 20653
Vibration	57.9 m/s ² to ISO 16750-3 chapter 4.1.2.7	
Shock	500 m/s ² :	ON position
	300 m/s ² :	OFF position
	to ISO 16750-3, chapter 4.2.2	

Technical data		
Chemical resistance to ISO 16750-5		
Oil, hydraulic liquids, alcohol, urea, extinguishing agents, battery acid ¹ , detergents, grease, cold cleaner		
¹ (except 48 V version)		
Corrosion	5 % salt mist to ISO 16750-4, chapter 5.5.1 severity 4	
Humidity	85 % RH to ISO 16750-4, chapter 5.7	
Flammability	meets the requirements to ECE-R 118 02 app. 6.7	
Dimensions	w x h x d (without terminals or flanges)	
	single pole, bistable 49.6 (62) x 91.3 x 45.8 [mm]	
Mass single pole	≤ 290 g	
Tightening torque values	M10 studs	15 Nm
	M8 studs	12 Nm
	M4 screws	2.0 Nm
	M5 side flange	6.0 Nm
Material		
Enclosure	Polyamide (PA), glass fiber reinforced	
Optional mounting plates	aluminium	
Main terminals	brass tin-plated	
Permanent magnets	Neodym	
Screws, washers, nuts	stainless steel	
Tightening torque values	M10 studs	15.0 Nm
	M8 studs	12.0 Nm
	M4 screws	2.0 Nm
	M5 side flange	6.0 Nm

Notes

- Terminal cross section:
- > 35 mm² for 100 A at M8
 - > 70 mm² for 200 A at M8/M10
 - > 95 mm² for 300 A at M10

The connecting cables must be firmly fixed by suitable means at the latest after 7 cm from the axis of the screw terminal. See drawing

The following exclusively applies to prototypes and pre-series production:

The technical design of the product and any enclosed documentation are preliminary.

- The technical data are subject to alterations.
- The indicated technical data must be observed.
- We cannot guarantee to manufacture and supply a product identical in construction.
- The release tests have not yet been completed.

- The product will only be available in substantial quantities after start of series production.
- Initial start-up of the product requires special care. Safety instructions need to be observed without fail.
- The product must only be used under laboratory conditions to reliably exclude any risk for life and limb, for machinery or other valuable goods in the event of malfunction or total failure.
- Prototype models or products are expressly not meant to be operated continuously and/or to remain unattended. Unless explicitly agreed otherwise, there is no guaranteed typical life or meantime to failure.
- The devices are intended to being tested with regard to their basic suitability for certain applications.
- They have no series approvals. They are not intended to be placed on the market.

5

Terminal drawing

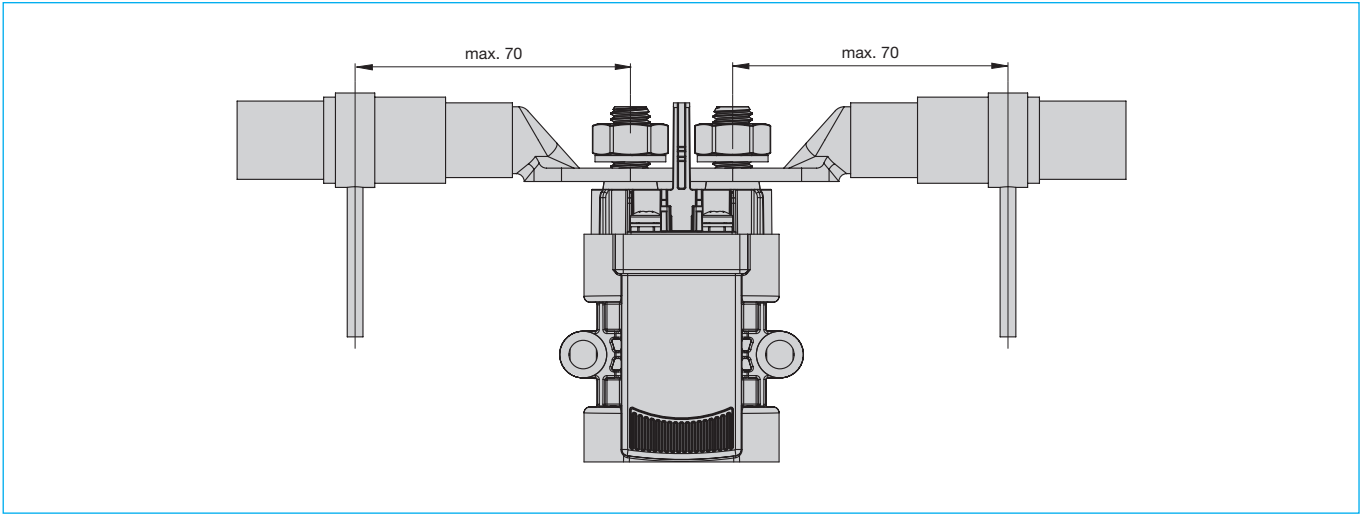

Dimensions (Design until July 2022)

Version without integral side flange for optional side and foot plate with M4 connectors

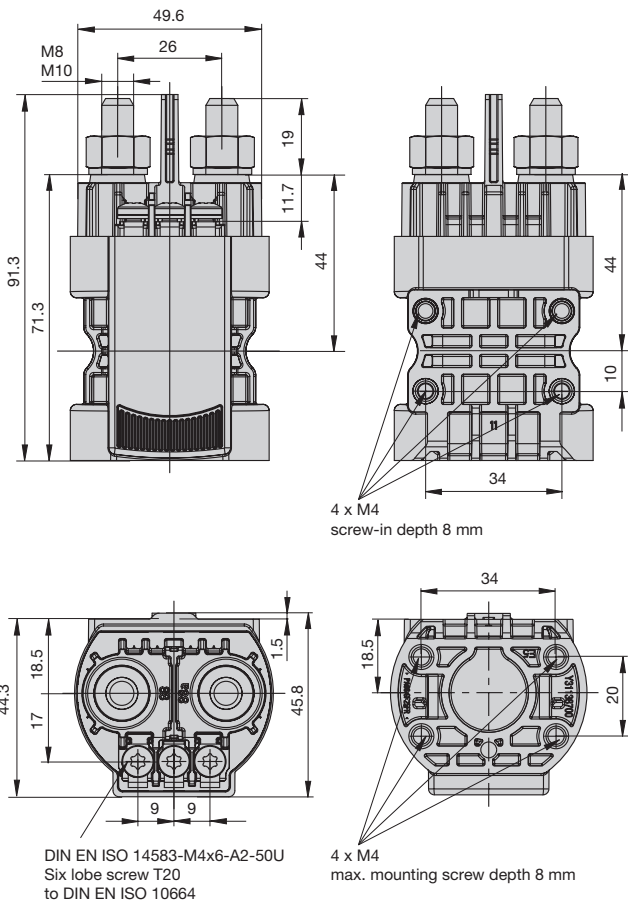

Version with side flange (50 mm distance between holes) and M4 screw terminals

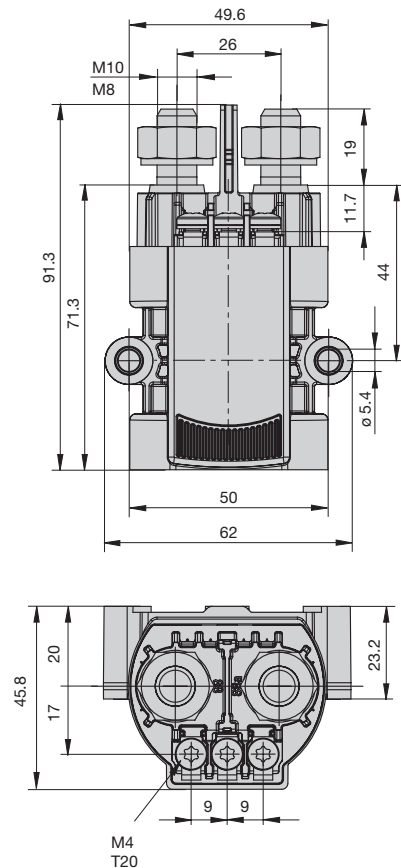

Dimensions (Design until July 2022)

Mounting method 1 including option 4 – 3-pole connector compatible with Tyco HDSCS

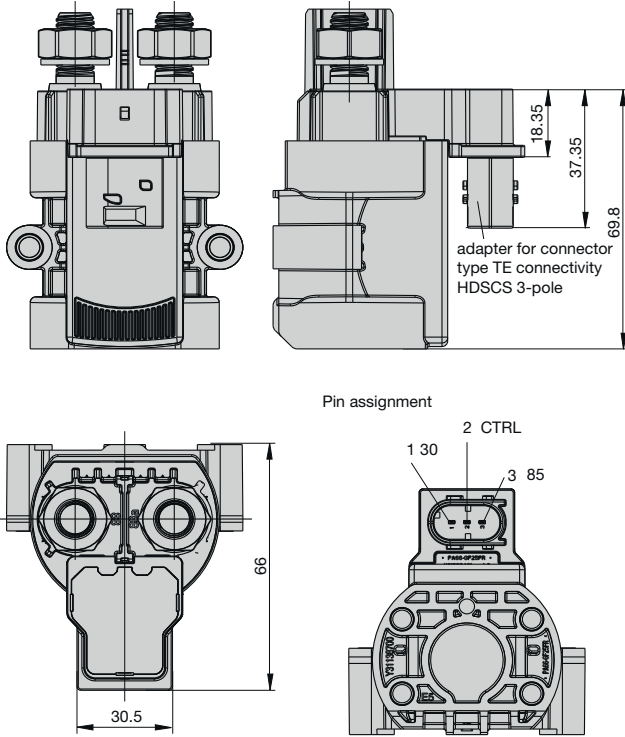

Dimensions HPR10 (Design from July 2022)

Mounting method 1 including side flange (50 mm hole spacing) and M4 screw terminals

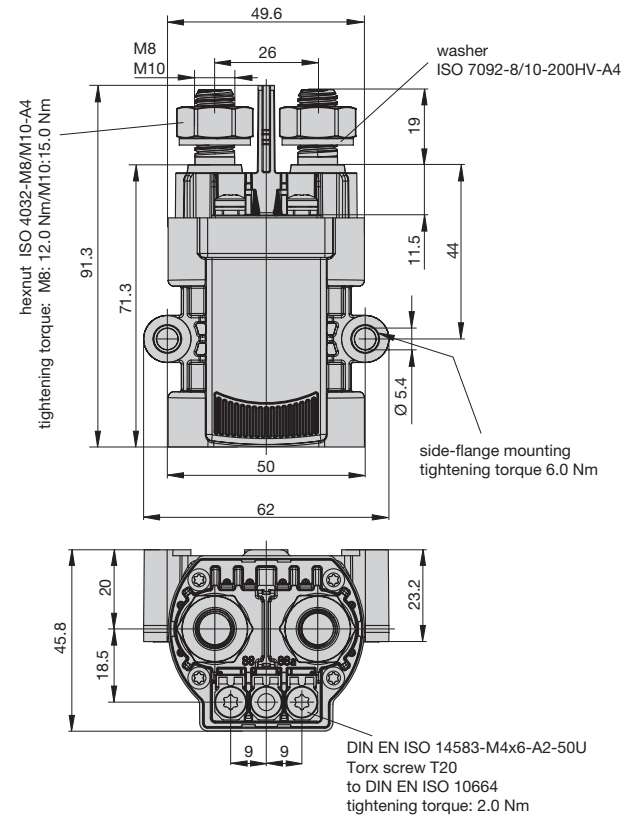

Dimensions HPR10 (Design from July 2022)

Mounting method 5: without integral side flange for optional side or foot plate with M4 connectors

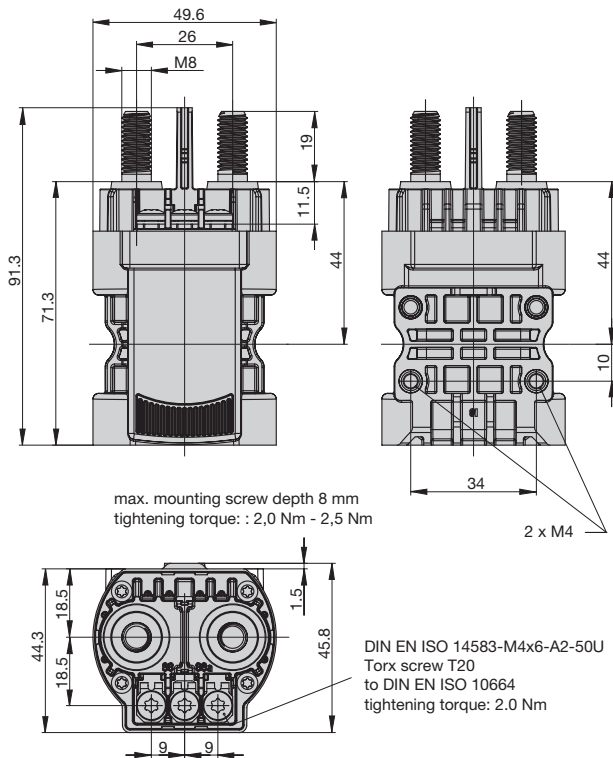

Mounting method 1 including option 4 – 3-pole connector compatible with Tyco HDSCS

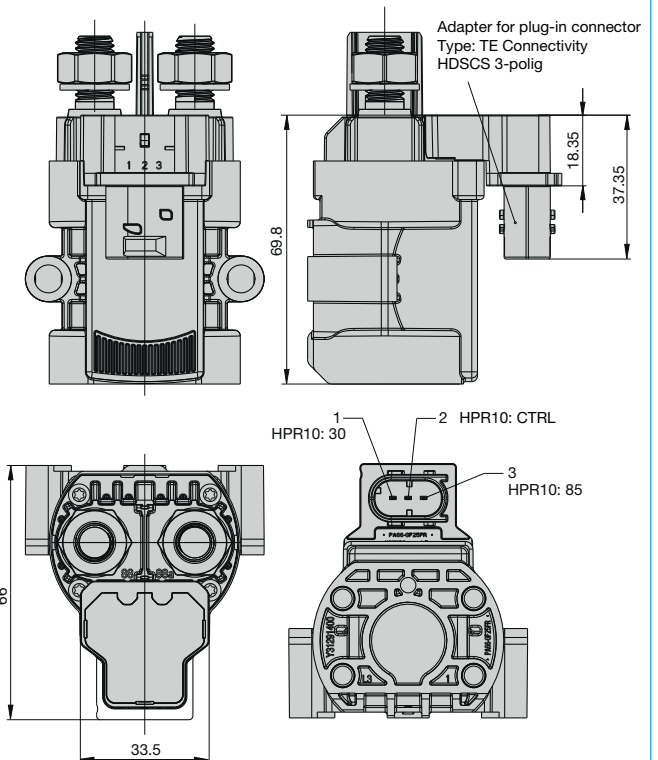

5

Functional description

The HPR is voltage level controlled. This means, it will be programmed ex-factory how it should work: either like a signal-controlled relay, practically as a monostable function, or with an impulse like a bistable relay and even with a defined voltage level. Delay times (T_{ON} or T_{OFF}) can be programmed in the microcontroller. The relay will then be switched on or off after a defined time. Measurement of the input signal is analog. This allows checking the system voltage. So for instance if the battery voltage falls below a certain programmed level (e.g. 5 V), the relay can open the main contact (automatic load shed). As soon as the level rises again (e.g. > 16 V) it will be switched back on.

Activation

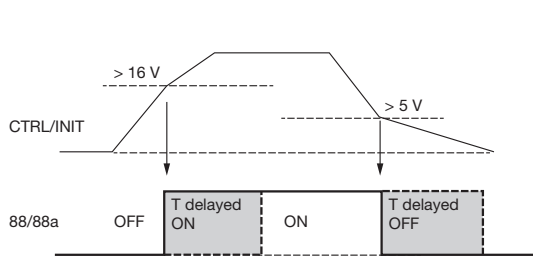

Activation:

There are two ways of activating the relay: level or pulse. The level activation requires a high signal being applied to the IN+ terminal so that the relay switches on the load. The low signal disconnects the load. With the pulse activation the relay alternately switches the load on and off with each pulse.

Level activation

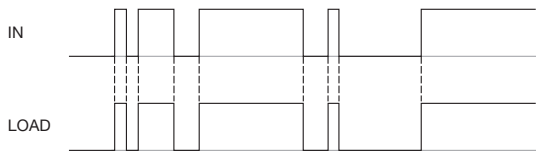

Pulse activation

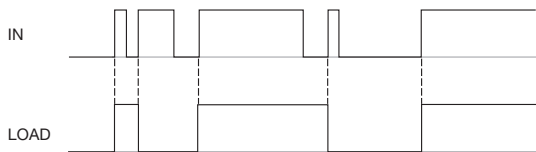

Filter function in the activation:

This function serves for tolerating disturbances on the activation line. Incidental peaks or contact chattering will then not cause inadvertent connection/disconnection of the load. The value configured for this function determines how long a control signal has to be applied permanently to the control input until it will be recognised as such. Should there be dips in the control signal during the configured time, it will not be recognised as activation. Information: Inadvertent activation can thus be prevented.

Level activation with filter function

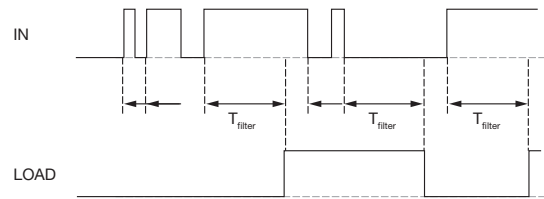

Pulse activation with filter function

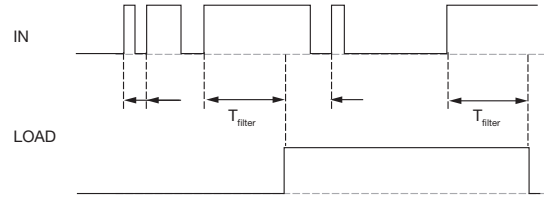

Low voltage detection:

This function serves for low voltage protection. If the voltage applied to the relay falls below the pre-set value (U_{OFF}), the load will be disconnected. If the voltage rises again, the relay can be switched on again either automatically at the pre-set value U_{ON} or otherwise the switch-on procedure has to be re-triggered. This would for instance prevent inadvertent start-up of a machine as requested by the current Machinery Directive. Low voltage detection is via internal tap (SENSE) at load contact 88.

Low voltage detection

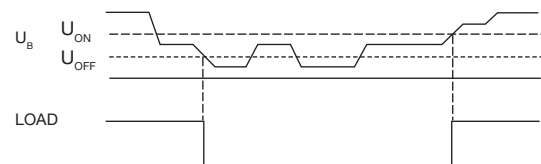

Behaviour in the event of reset of the operating voltage will be configured. Automatic ON or OFF

Caution: If e.g. an extreme discharge of the battery has the system voltage fall very quickly below the critical value, the electronic circuitry does not have enough time and energy to switch the relay. We recommend to set the status to a safe condition as soon as the operating voltage is restored, i.e. to the OFF condition.

ON/OFF switching delay

The relay features a timer function allowing delayed switch on or off of the load, e.g. for applications with exhaust aftertreatment (SCRT catalytic converters).

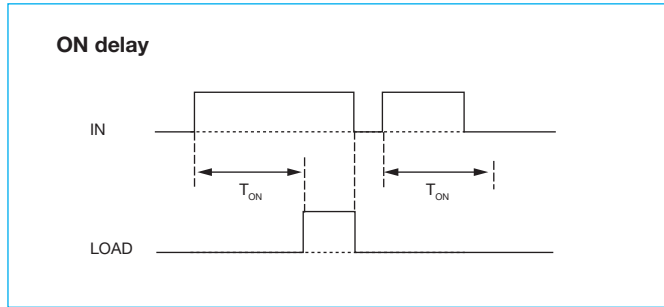

This function allows delayed switch-on of the relay. The configured value indicates the time elapsing between activation and switch-on. Information: Thus, the relay may for instance give time to other system components to carry out their start-up, probably attenuating the inrush current peak in the entire system.

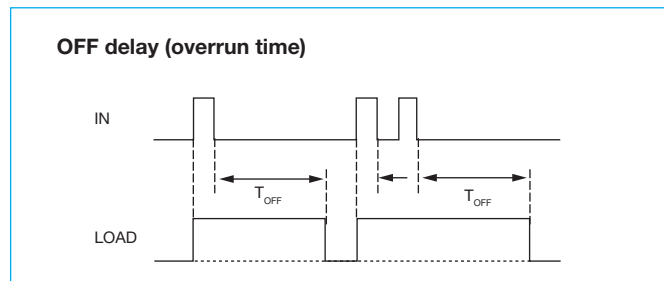

This function allows delayed switch-off of the relay. The configured value indicates the time elapsing between activation and switch-off. Information: An overrun is desired in many applications, e.g. to give some orientation with illuminations even after switch-off or to give a load enough time to complete the switch-off process.

Schematic diagram

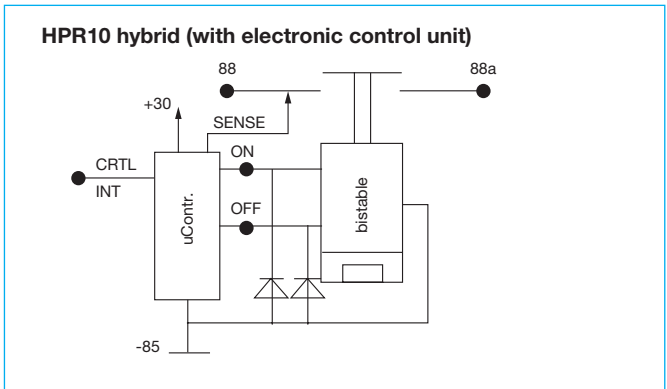

Configurator

A programme for configuring the HPR10 is available on the E-T-A website. It allows selection of various functions and sets up the corresponding ordering code.

<http://relaisconfigurator.e-t-a.com/light/de/>